

<b>SUBMITTAL DATA SHEET</b>	<b>CH-12MSPHCT-230VI</b>	<b>CH-HYP12SPH230VO</b>
-----------------------------	--------------------------	-------------------------

Job Name: .....  
 Location: .....  
 Engineer: .....  
 Submitted to: .....  
 Submitted by: .....  
 Reference: .....

Date: .....  
 Approval: .....  
 Construction: .....  
 Unit #: .....  
 Drawing #: .....



This warranty should be registered on our web-site [www.cooperandhunter.us](http://www.cooperandhunter.us) within 60 days of installation. The warranty is only valid when installed by a Licensed HVAC Technician. A warranty period of Seven (7) years on compressor to the original registered end-user. A warranty period of Five (5) years on all parts to the original registered end user. Warranty applies only to products remaining in their original installation location.

Heating/ Cooling	Outdoor Dry Bulb	Indoor Dry Bulb	Unit	Min	Rated	Max
Heating	5°F	70°F	Btu/h	1,845	-	10,621
			kW	0.34	-	1.78
			COP	1.59	-	1.75
	17°F	70°F	Btu/h	2,860	8,700	13,136
			kW	0.36	0.95	1.95
			COP	2.33	2.68	1.97
	47°F	70°F	Btu/h	4,759	12,000	16,015
			kW	0.3	0.96	1.46
			COP	4.65	3.66	3.21
Cooling	82°F	80°F	Btu/h	4,167	-	14,196
			kW	0.15	-	0.87
			COP	8.14	-	4.78
	95°F	80°F	Btu/h	3,272	12,000	14,016
			kW	0.22	0.96	1.39
			COP	4.36	3.66	2.96

### INDOOR SPECIFICATION

Air Flow (Hi/Mi/Lo)	338/288/248 CFM
Noise Level (Hi/Mi/Lo)	41/38/35 dB(A)
Unit Dimension (WxDxH)	22.44x22.44x10.24 in
Net/Gross Weight	35.27/41.88 lb

### OUTDOOR SPECIFICATION

Air flow	1177 CFM
Noise Level	56 dB(A)
Dimension (WxDxH)	31.50x13.11x21.81 in
Net/Gross weight	88.2/93.7 lb
Refrigerant type/Quantity	R410A/52.9 oz
Refrigerant precharge	25 ft
Additional charge for each ft	0.16 oz

### PERFORMANCE AND EFFICIENCY

Cooling		Heating	
12,000 Btu/h		12,000 Btu/h	
SEER	19.5	HSPF Region IV	10.6
EER	12.5		

### OPERATION TEMPERATURE RANGE

Indoor		Outdoor	
cooling	heating	cooling	heating
62~90°F	32~86°F	-22~122°F	-22~86°F

### ELECTRICAL

Power supply	208-230V/ 60Hz, 1Ph
MCA	9 A
MFA	15 A

**MCA:** Minimum Circuit Ampacity **MFA:** Max. fuse A

### PIPING

Refrigerant piping Liquid side/Gas side	1/4 - 1/2 in
Max. refrigerant pipe length	82 ft
Max. difference in level	33 ft

SUBMITTAL DATA SHEET

CH-12MSPHCT-230VI

CH-HYP12SPH230VO

### INDOOR UNIT

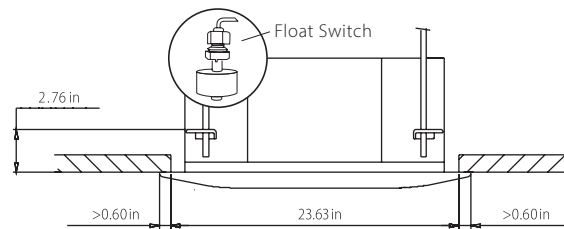
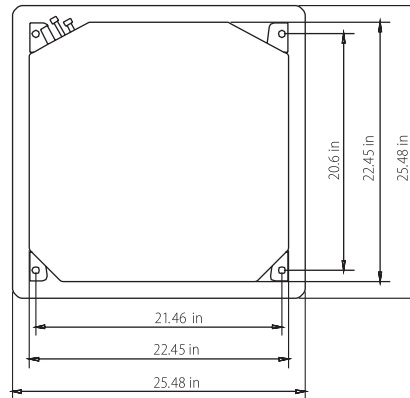
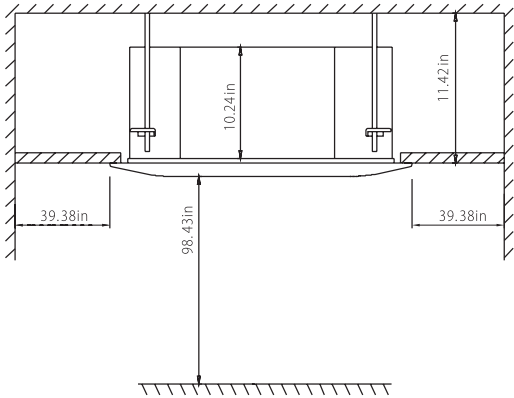

### OUTDOOR UNIT

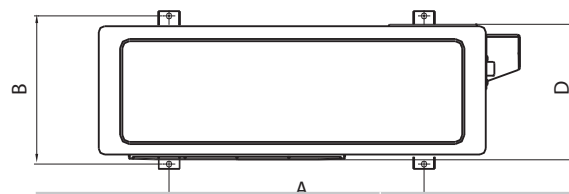
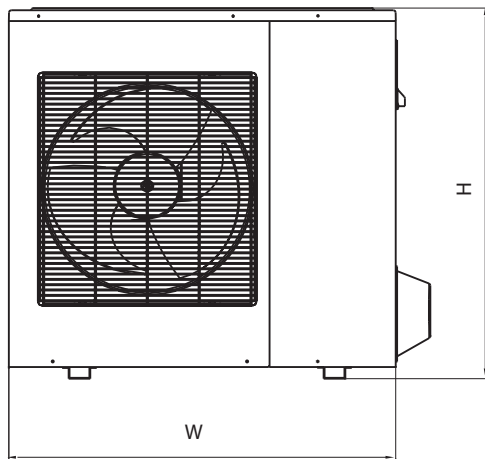

Outdoor Unit Dimensions WxDxH	Mounting Dimensions	
	Distance A	Distance B
31.5x13.11x21.81	20.24	13.39